



OLFA®

THE ORIGINATOR SINCE 1956

PRODUCTS GUIDE NO.179



■ The OLFA snap-off blade cutter, invented in 1956, is the proven best selling and fastest moving cutting tool in the world.

- Le cutter OLFA à lame sécable, inventé en 1956 est de loin l'outil de coupe le plus rapide à manipuler et le plus vendu à travers le monde.
- Das OLFA-Abbrechmesser, das 1956 erfunden wurde, ist nachweislich das bestverkaufte und am weitesten verbreitete Schneidwerkzeug auf der Welt.
- El cortador OLFA de cuchillas desglósables, inventado en 1956 es el cortador más vendido y el de mayor velocidad de corte del mundo.



Mr. Yoshio OKADA (1931-1990)
The founder of OLFA CORPORATION

■ Feel The Difference in Sharpness and durability!

- Sentez la différence en termes de précision et de durée!
- Spüren Sie den Unterschied in Schärfe und Strapazierfähigkeit!
- ¡Sienta la diferencia en afilado y duración!

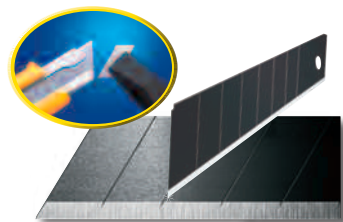

| | | | | | |
|--|--|--|---|--|---|
| | <ul style="list-style-type: none"> ■ PACKAGING ■ EMBALLAGE ■ VERPACKUNG ■ EMBALAJE | | <ul style="list-style-type: none"> ■ REPLACEMENT BLADE ■ LAME de RECHANGE ■ ERSATZKLINGE ■ CUCHILLA de REPUESTO | | <ul style="list-style-type: none"> ■ CARTON CONTENTS ■ CONTENU du CARTON ■ KARTONINHALT ■ CONTENIDO de EMBALAJE |
|--|--|--|---|--|---|

| | | | |
|--|--|--|--|
| <ul style="list-style-type: none"> ■ BLISTER PACKED ■ EMBALLAGE BLISTER ■ BLISTER PACKUNG ■ PRESENTADO en BLISTER <ul style="list-style-type: none"> ■ PLASTIC BAG ■ SACHET PLASTIQUE ■ KUNSTSTOFFBEUTEL ■ BOLSA de PLÁSTICO <ul style="list-style-type: none"> ■ PLASTIC CASE ■ ÉTUI PLASTIQUE ■ KUNSTSTOFFBOX ■ CAJA de PLÁSTICO | <ul style="list-style-type: none"> ■ QUALITY/SAFETY CERTIFIED PRODUCT IN GERMANY ■ PRODUIT CERTIFIÉ QUALITÉ/SECURITE EN ALLEMAGNE ■ QUALITÄT/SICHERHEIT DES PRODUKETS WURDEN IN DEUTSCHLAND STAATLICH GEPRÜFT ■ PRODUCTO CON CALIDAD/SERURIDAD CERTIFICADA EN ALEMANIA | <ul style="list-style-type: none"> ■ STAINLESS STEEL BLADE ■ LAME ACIER INOXIDABLE ■ KILNGE AUS ROSTFREIEM ■ CUCHILLA de ACERO INOXIDABLE | |
| | <ul style="list-style-type: none"> ■ THE GOOD DESIGN AWARDED PRODUCT ■ PRIME MELLEUR PRODUIT POUR SON -EXCELLENT DESIGN ■ DIESES PRODUKT WURDE MITDEM "GOOD DESIGN" PREIS AUSGEZEICHNET ■ PRODUCTO PREMIADO POR SU "BUEN DISEÑO" | <ul style="list-style-type: none"> ■ COMFORT GRIP ■ CONFORT GRIP ■ COMFORT GRIP ■ MANGO CÓMODO | |
| | <ul style="list-style-type: none"> ■ AUTO-LOCK ■ VERROUILLAGE AUTOMATIQUE ■ AUTO-LOCK KLINGENFESTSTELLER ■ BLOQUEO AUTOMATICO | <ul style="list-style-type: none"> ■ ACID AND ACETONE RESISTANT ■ RÉSISTANT À L'ACIDE ET À L'ACÉTONE ■ SAÛRE UND AZETON BESTÄNDIG ■ RESISTENTE AL ÁCIDO Y A LA ACETONA | |
| | <ul style="list-style-type: none"> ■ NEW ■ NOUVEAU ■ NEU ■ NUEVO | <ul style="list-style-type: none"> ■ PATENTED ■ BREVETÉ ■ PATENTADO ■ PATENTIERT | |
| | <ul style="list-style-type: none"> ■ FOR BOTH RIGHT- and LEFT- HANDED USERS ■ POUR UTILISATEURS GAUCHERS ET DROITIERS ■ FÜR RECHTS- und LINKSHÄNDER ■ PARA USUARIOS DIESTROS Y ZURDOS | <ul style="list-style-type: none"> ■ PATENT PENDING ■ EN ATTENTE DE BREVET ■ PATENTE PENDIENTE ■ ANGEMELDETES PATENT | |
| <ul style="list-style-type: none"> ■ ULTRA SHARP BLADE ■ LAME ULTRA AIGUISÉE ■ ULTRA-SHARFE KLINGE ■ CUCHILLA ULTRA AFILADA | | | |

Extra Heavy-Duty Models **25** mm



XH-1 **HB/HBB** **6x12**
 X-Design, superior cutting force. X-Design, bessere Schneidekraft.
 Conception-X, force de coupe supérieure. Diseño X, fuerza de corte superior.



H-1 **HB/HBB** **6x20**
 With large cushion rubber. Mit großer Unterplatte.
 Avec un grand tampon en caoutchouc. Con almohadilla de caucho de gran tamaño.

NH-1 **HB/HBB** **6x20**
 Anti-Slip Elastomer handle. Rutschfester Elastomergriff.
 Poignée en élastomère antidérapante. Mango de elastómero antideslizante.

Heavy-Duty Models **18** mm



L-5 **LB/LBB/LBD/LSOL** **6x20**
L5-AL **LB/LBB/LBD/LSOL** **6x20**
 X-Design, superior cutting force. X-Design, bessere Schneidekraft.
 Conception-X, force de coupe supérieure. Diseño X, fuerza de corte superior.



AUTO LOCK



L-1 **LB/LBB/LBD/LSOL** **6x20**
 Best and longest selling model. Das beste und am längsten verkaufte Modell.
 Modèle le plus vendu depuis longtemps. El modelo de mayor y mejor venta.



L-2 **LB/LBB/LBD/LSOL** **6x20**
 With large cushion rubber. Mit großer Unterplatte.
 Avec un large tampon en caoutchouc. Con almohadilla de caucho de gran tamaño.

New

With detachable blade snapper/disposal case.

- Avec casse-lame/boite de lames usagées.
- Mit Klingenschnapper/Entsorgungsbehälter.
- Con desglosador de cuchillas/ estuche para descarte.



AUTO LOCK

DL-1



LB/LBB/LBD

PAT.P



6x20

Auto-loading up to 6 blades.

- Chargement automatique jusqu'à 6 lames.
- Automatisches Laden mit bis zu 6 Klingen.
- Carga automática de hasta 6 cuchillas.

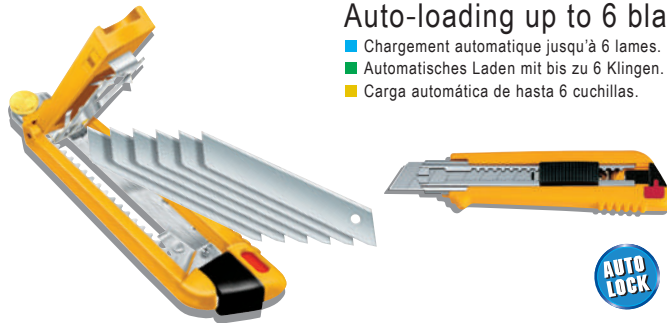

AUTO LOCK

PL-1



LB/LBB/LBD/LSOL

PAT



6x20

Anti-Slip elastomer handle.

- Poignée en élastomère antidérapante.
- Rutschfester Elastomergriff.
- Mango de elastómero antideslizante.



NOL-1



LB/LBB/LBD/LSOL

PAT



COMFORT GRIP

ACETONE RESISTANT



6x20

NL-AL



LB/LBB/LBD/LSOL

PAT

VPA

GS

COMFORT GRIP

ACETONE RESISTANT



6x20

Versatile models in ergonomic design.

- Modèle polyvalent à la conception ergonomique.
- Vielfältiges Modell im ergonomischen Design.
- Modelo versátil de diseño ergonómico.



BN-L



LB/LBB/LBD/LSOL

PAT

VPA

GS



6x20

BN-AL



LB/LBB/LBD/LSOL

VPA

GS



6x20

AUTO LOCK

ML



LB/LBB/LSOL



6x20

- With metal handle.
- Avec poignée en métal.

- Mit Metallgriff.
- Con mango metálico.

AUTO LOCK

EXL



LB/LBB/LBD/LSOL



6x20

- High cost-performance model.
- Modèle d'un excellent rapport qualité-prix.

- Preis-Leistungs-Modell.
- Modelo de alto rendimiento.

VPA

GS



SL-1

LB/LBB/LSOL



6x20

- With unique tractor locking system.
- Avec système de verrouillage par traction unique.
- Mit einzigartigem Schleppverriegelungssystem.
- Con sistema de bloqueo tractor único.



L-3

LB/LBB/LBD

6x20

- For both tough & fine cutting.
- Pour une découpe à la fois fine et difficile.
- Sowohl für grobes als auch für feines Schneiden.
- Tanto para cortes precisos como para cortes difíciles.

With extended blade channel & steel tucker.

- Avec conduit de lame prolongé et corps en acier.
- Mit erweitertem Klingenkanal & Stahl-Falzmesser.
- Con canal para cuchilla amplio y paleta de acero.

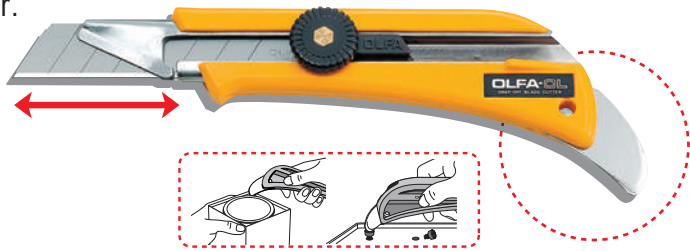

OL

LB/LBB/LBD/LSOL

6x20



- For jobs requiring extra reach.
- Für Arbeiten mit einem größeren Wirkungsbereich.
- Pour des travaux nécessitant une grande flexibilité.
- Para aquellos trabajos que requieran de mayor alcance.



XL-2

LB/LBB/LBD/LSOL

6x10

With spacer & staple remover.

- Avec entretoise et dégrafeur.
- Mit Abstandshalter & Enthefter.
- Con espaciador y extractor de grapas.



CL

LB/LBB/LBD/LSOL



6x20

Long blade sheath & manual lock.

- Gaine pour lame longue et verrouillage manuel.
- Lange Klingenscheide & manuelles Schloss.
- Estuche para cuchilla largo y bloqueo manual.

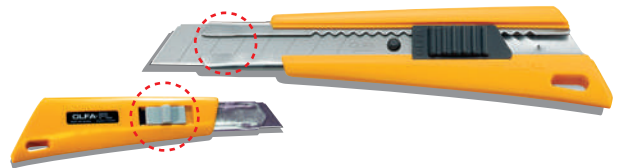

FL

LB/LBB/LSOL

6x20

Circle cutter for dia. 7-30cm.

- Cutter circulaire pour diamètre de 7 à 30 cm.
- Kreismesser für Durchmesser. 7-30 cm.
- Cortador circular para diámetros de 7 a 30 cm.



CMP-2

LB/LBB/LBD



5x10

Powerful cutting with two hands.

- Coupe puissante avec les deux mains.
- Kraftvolles Schneiden mit zwei Händen.
- Corte potente con dos manos.



LL

LB/LBB/LBD/LSOL

6x10



Standard-Duty Models

9
mm

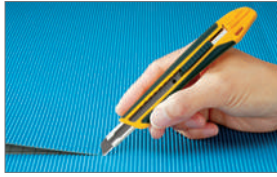

X-Design, superior cutting force.

- Conception-X, force de coupe supérieure.
- X-Design, bessere Schneidkraft.
- Diseño X, fuerza de corte superior.



XA-1



AB/ABB/AB-S



With original one-way locking system.

- Avec système de verrouillage à sens unique.
- Mit einseitigem Verriegelungssystem.
- Con sistema de bloqueo unidireccional.



A-5



AB/ABB/AB-S



With 30-degree angle blade.

- Avec lame d'angle à 30 degrés.
- Mit 30 Grad Winkelklinge.
- Con cuchilla en ángulo de 30 grados.



SAC-1



SAB



All stainless steel models.

- Tous les modèles en acier inoxydable.
- Modell komplett aus Edelstahl.
- Todos los modelos son de acero inoxidable.



SVR-2



AB-S/AB/ABB



SVR-1



AB-S/AB/ABB



A



AB/ABB/AB-S



- Basic model with blade snapper/clip.
- Modèle de base avec casse-lame/clip.
- Grundmodell mit Klingenschnapper/Clip.
- Modelo básico con desglorador de cuchilla/clip.



A-3



AB/ABB/AB-S



- Two-way cutter.
- Zweiseitiges Messer.
- Cutter double-sens.
- Cuchilla bidireccional.



A-2



AB/ABB/AB-S



- Basic model with rubber grip.
- Grundmodell mit Gummigriff.
- Modèle de base avec poignée en caoutchouc.
- Modelo básico con mango de caucho.

180-BT/36

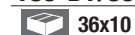

180 Black



AB/ABB/AB-S



- Metal handle with blade snapper/clip.
- Metallgriff mit Klingenschnapper/Clip.
- Poignée métallique avec casse-lame/clip.
- Mango metálico con desglorador de cuchillas/clip.



With detachable blade snapper/disposal case.

- Avec casse-lame/boîte de lames usagées.
- Mit Klingenschnapper/Entsorgungsbehälter.
- Con desglosador de cuchillas/ estuche para descarte.



New

AUTO LOCK

DA-1

FOR BOTH RIGHT- and LEFT-HANDED USERS

AB/ABB/AB-S 6x40

Auto-loading up to 5 blades.

- Chargement automatique jusqu'à 5 lames.
- Automatisches Laden mit bis zu 5 Klingen.
- Carga automática de hasta 5 cuchillas.

EXCELBLACK
ULTRA SHARP BLADE



AUTO LOCK

PA-2

Long Selling

AB/ABB/AB-S 6x40

AUTO LOCK



NA-1

COMFORT GRIP™
ACETONE RESISTANT

AB/ABB/AB-S 6x40

- Anti-Slip Elastomer handle.
- Rutschfester Elastomergriff.
- Poignée élastomère antidérapante.
- Mango de elastómero antideslizante.



300

AB/ABB/AB-S 6x20

- With screw locking system.
- Mit Schraubenverriegelungssystem.
- Avec système de verrouillage à vis.
- Con sistema de bloqueo de tornillo.

S

AB/ABB/AB-S 6x80

- Slim metal body with blade snapper/clip.
- Corps en métal allégé avec casse-lame/clip.
- Schlanker Metallkörper mit Klingenschnapper/Clip.
- Cuerpo metálico fino con desglosador de cuchilla/clip.

S/20 VPA GS
20x30

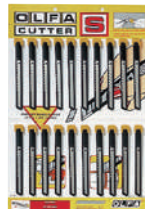

SPC-1/40

AB/ABB/AB-S 40x20

- High cost-performance model.
- Preis-Leistungs-Modell.
- Modèle d'un excellent rapport qualité-prix.
- Modelo de alto rendimiento.

Medium-Sized Models **12.5 mm**

The most versatile cutter.

- Le cutter le plus polyvalent.
- Das vielseitigste Messer.
- El cortador más versátil.

0.45 mm



AUTO LOCK

MT-1

FOR BOTH RIGHT- and LEFT-HANDED USERS

MTB 6x40

Thinner blade wallcovering cutter.

- Cutter à lame plus fine pour revêtement mural.
- Dünneres Klingen-Wandverkleidungsmesser.
- Cortador fino con cuchilla para revestimiento de pared.

0.25 mm

For Wallcovering

EXCELBLACK
ULTRA SHARP BLADE



AUTO LOCK

FWP-1

Long Selling

FWB 6x40

Safety Models

SAFETY FIRST



New



SK-10



SKB-10

6x20

- Stretch Wrap Cutter
- Streckverpackungs messer
- Cutter extensible pour emballage
- Cutter para flejes y films



CLICK



SK-8



SKB-8

6x20

- Automatic self-retracting system.
- Automatisches selbststeinziehendes System.
- Système auto-rétractable automatique.
- Sistema auto-retráctil automático.

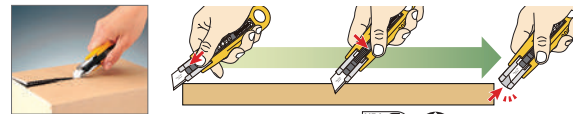

SK-4



SKB-2/RSKB-2/HOB-2

6x20

- The best selling safety cutter.
- Das meistverkaufte Sicherheitsmesser.
- Le cutter de sécurité le plus vendu.
- El cortador de seguridad más vendido.



SK-5



SKB-2/RSKB-2/HOB-2

6x20

- Anti-Slip Elastomer handle.
- Rutschfester Elastomergriff.
- Poignée en élastomère antidérapante.
- Mango de elastómero antideslizante.



SK-6



RSKB-2

6x20

- Automatic protection guard.
- Automatische Schutzeinrichtung.
- Carter de protection automatique.
- Cubierta de protección automática.



SK-7



SKB-7

6x20

- Compact safety cutter.
- Kompaktes Sicherheitsmesser.
- Cutter de sécurité compact.
- Cortador de seguridad compacto.



SK-9



SKB-2/RSKB-2/HOB-2

6x20

- With metal tape slitter.
- Mit Metall-Bandlängsschneider.
- Avec découpeuse à ruban métallique.
- Con cortador de cinta de metal.

Blade Disposal Cases

For safety, environment & convenience. For getting a fresh cutting point comfortably & safely.

- Par mesure de sécurité, pour des raisons environnementales et de convection. Pour obtenir confortablement et en toute sécurité des points de coupe nets.
- Für Sicherheit, Umwelt & Komfort. Für das bequeme & sichere Erlangen eines frischen Schneidepunktes.
- Por motivos de seguridad, medioambiente y conveniencia. Para obtener un punto de corte preciso, confortable y seguro.



DC-1

10x20



DC-2

Paper Box
6x20



DC-3

10x20



DC-4

Paper Box
6x40



- Environment-Friendly cutters made from recycled material. Equal durability and blade sharpness with regular version respectively.
- Respectueux de l'environnement, cutters fabriqués à partir de matériaux recyclés. Durabilité et affûtage de la lame équivalents à la version normale.
- Umweltfreundlich, Messer aus recyceltem Material. Gleiche Haltbarkeit und Klingenschärfe mit der regulären Version.
- Cuchillas ecológicas hechas de materiales reciclados. La misma durabilidad y afilado que la versión regular.



L-1/green

LB/LBB/LBD/LSOL 6x20

- Green version of the best seller.
- Öko-Version des Bestsellers.
- Version écologique du produit phare.
- Versión ecológica del más vendido.



ES-1/green

AB/ABB/AB-S 6x40

- Enables to disassemble into 5 parts for recycling.
- Permet de démonter en 5 parties pour le recyclage.
- Kann zum Recyceln in 5 Teile auseinandergenommen werden.
- Permite su desmantelamiento en 5 partes para su reciclaje.



SK-4/green

SKB-2/RSKB-2/HOB-2 6x20

- Green version of the popular safety cutter.
- Öko-Version des beliebten Sicherheitsmessers.
- Version écologique du cutter de sécurité populaire.
- Versión ecológica de la popular cuchilla de seguridad.



SK-7/green

SKB-7 6x20

- Compact safety cutter.
- Kompaktes Sicherheitsmesser.
- Cutter de sécurité compact.
- Cortador de seguridad compacto.

Scrapers

Heavy-duty scrapers can be used in construction site.

- Les grattoirs pour gros travaux peuvent être utilisés sur les chantiers.
- Stabile Schabmesser können auf Baustellen verwendet werden.
- Los raspadores industriales pueden utilizarse en obras de construcción.



BSR-200

BS/BSF/LB 5x10

- 200 mm long.
- 200 mm Länge.
- Longueur : 200 mm
- Longitud de 200 mm.



BSR-300

BS/BSF/LB 5x10

- 300 mm long.
- 300 mm Länge.
- Longueur : 300 mm
- Longitud de 300 mm.

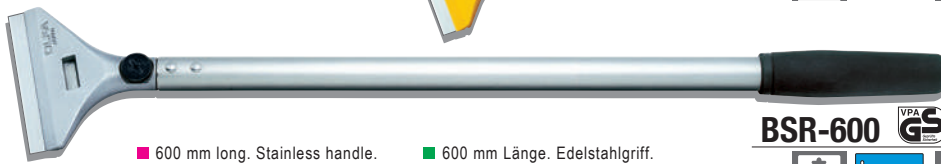

BSR-600

BS/BSF/LB 5x6

- 600 mm long. Stainless handle.
- 600 mm Länge. Edelstahlgriff.
- Longueur : 600 mm Poignée en inox.
- Longitud de 600 mm. Mango de acero inoxidable.

Compact scrapers for cleaning floor & glass top oven.

- Grattoirs compacts pour le nettoyage des sols et des fours à porte en verre.
- Kompakt-Schabmesser zum Reinigen des Bodens & der Ofenglasdecke.
- Raspadores compactos para la limpieza de suelos y cubiertas de cristal de hornos.

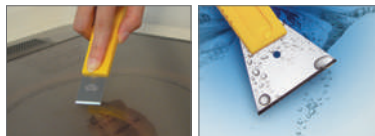

SCR-S

6x20

- Blade width: 25mm
- Klingenbreite: 25 mm
- Largeur de la lame : 25 mm
- Anchura de la cuchilla: 25 mm



SCR-M

6x20

- Blade width: 43mm
- Klingenbreite: 43mm
- Largeur de la lame : 43mm
- Anchura de la cuchilla: 43mm



SCR-L

6x20

- Blade width: 60mm
- Klingenbreite: 60mm
- Largeur de la lame : 60mm
- Anchura de la cuchilla: 60mm

Knife-edged scraper for scraping glass & cutting leather.

- Grattoir à bord tranchant pour gratter le verre et découper le cuir.
- Messerschneiden-Schabmesser zum Schaben von Glas & Schneiden von Leder.
- Raspador con filos de cortador para raspar cristal y cortar cuero.



BTC-1

BTB-1 6x20

Handy scrapers with unique multi-edged arc blade.

- Grattoir maniable avec lame en arc multi-tranchants.
- Handliches Schabmesser mit mehrschneidiger Bogenklinge
- Raspador práctico con cuchilla de arco de varios filos.

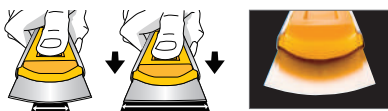

T-25

TB-25 6x20

- Blade width: 25mm
- Klingenbreite: 25mm
- Largeur de la lame : 25mm
- Anchura de la cuchilla: 25mm



T-45

TB-45 3x40

- Blade width: 45mm
- Klingenbreite: 45 mm
- Largeur de la lame : 45mm
- Anchura de la cuchilla: 45mm

Rotary Cutters

Loved by many quilters and craft enthusiasts around the world since the launch in 1979. Simple and basic functions assist user's creativity for long years.

- Apprécié par de nombreux artisans et amateurs de bricolage dans le monde depuis sa mise sur le marché en 1979. Ses fonctions de base simples aident à la créativité de son utilisateur depuis de longues années.
- Von vielen Quilt-Herstellern und Handwerksbegeisterten weltweit seit der Einführung 1979 geliebt. Einfache und grundlegende Funktionen unterstützen über viele Jahre die Kreativität des Benutzers.
- Adorado por muchos entusiastas de la artesanía y costura de todo el mundo desde su lanzamiento en 1979. Funciones simples y básicas para ayudar durante muchos años a la creatividad del usuario.



**60mm
RTY-3/G**



RB60

6x20

- Largest model with powerful blade.
- Größtes Modell mit kraftvoller Klinge.
- Modèle le plus grand avec lame puissante.
- El mayor modelo con una poderosa cuchilla.



**45mm
RTY-2/G**



RB45

6x20

- Basic model for wide applications.
- Modèle de base pour de multiples applications.
- Grundmodell für umfangreiche Anwendungen.
- Modelo básico para numerosas aplicaciones.



**28mm
RTY-1/G**



RB28/PRB28

6x20

- Small model with 28 mm blade.
- Kleines Modell mit 28 mm Klinge.
- Petit modèle avec lame de 28 mm.
- Modelo reducido con cuchilla de 28 mm.



**18mm
RTY-4**



RB18/PRB18

6x20

- For detailed works.
- Für detaillierte Arbeiten.
- Pour travaux détaillés.
- Para trabajos detallados.



Safety locking system. Designed for reducing hand fatigue and potential injuries at working place.

- La série DX dispose d'un système de verrouillage de sécurité. Conçu pour réduire la fatigue manuelle et les blessures potentielles sur le lieu de travail.
- Die DX-Reihe bietet ein Sicherheitsverriegelungssystem. Entwickelt, um die Handermüdung und potentielle Verletzungen am Arbeitsplatz zu verringern.
- La serie DX posee un sistema de bloqueo de seguridad. Diseñado para reducir el cansancio de la mano y posibles lesiones durante el trabajo.



**45mm
RTY-2/DX**



RB45/PIB45/WAB45

6x20

- With 45 mm blade, can accommodate decorative blades as well.
- Avec une lame de 45 mm, peut s'adapter aux lames décoratives.
- Mit 45 mm Klinge, kann dekorative Klingen unterbringen.
- Con cuchilla de 45 mm, puede acomodar cuchillas decorativas.



**60mm
RTY-3/DX**



RB60

6x10

- Large model with 60mm blade.
- Großes Modell mit 60 mm Klinge.
- Grand modèle avec lame de 60 mm.
- Modelo superior con cuchilla de 60 mm.



The combination of quick blade changing system, split blade cover and ergonomic comfort Grip.

- Combinaison d'un système de changement de lame rapide, d'un étui pour lame divisée et d'une poignée ergonomique confortable.
- Die Kombination aus schnellem Klingen-Wechselsystem, Schnappmesser-Abdeckung und ergonomischen Komfortgriff.
- Combinación del sistema de recambio rápido de cuchilla, cubierta de cuchilla desglosable y mango ergonómico cómodo.



**45mm
RTY-2/NS**



RB45

6x12

- Perfect for multiple use.
- Perfekt für Mehrfachnutzung.
- Idéal pour un usage multiple.
- Perfecto para diversos usos.



**60mm
RTY-3/NS**



RB60

6x10

- Large model with 60 mm blade.
- Großes Modell mit 60 mm Klinge.
- Grand modèle avec lame de 60 mm.
- Modelo superior con cuchilla de 60 mm.



PIK-2



PIB45/WAB45

6x20

- Rotary Pinking Cutter.
- Rund - Zackenschneider.
- Cutter circulaire à cranter.
- Cortador giratorio dentado.



WAC-2



WAB45/PIB45

12x10

- Rotary Wave Cutter.
- Rundes Wellenmesser.
- Cutter circulaire type Vague.
- Cortador giratorio para ondulados.



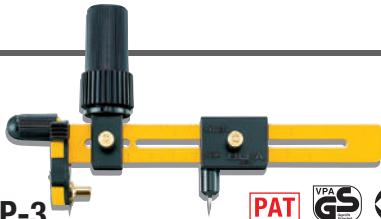

CMP-3



PAT



STAINLESS STEEL BLADE



- Cutting fabrics in circle in dia. 4-22mm
- Schneidet Stoffe im Kreis im Durchm. 4-22 mm
- Découpe de tissus en cercle de diamètre de 4 à 22 mm
- Corta telas en círculos de un diámetro de 4-22 mm



CHN-1



PAT



- Chenille cutter with 4 channel guides. With carrying case.
- Chenille-Messer mit 4 Führungskanälen. Mit Tragetasche.
- Cutter chenille avec 4 guides de conduit. Avec étui de transport.
- Cortador de felpa con 4 guías de canal. Con funda para transporte.

Quilt Rulers

shrink wrap



Non-slip, frosted surface acrylic rulers. Legible grid lines on both light and dark colored fabrics.



- Règle en acrylique avec surface dépolie antidérapante. Lignes de la grille lisibles à la fois sur les tissus de couleur claire et foncée.
- Rutschfest, mattierte Oberfläche Acryllineale. Lesbare Gitterlinien sowohl auf hellen als auch auf dunkelfarbigen Stoffen.
- Reglas acrílicas de superficie mate anti deslizantes. Líneas de cuadrícula legibles en telas con colores oscuros y claros.

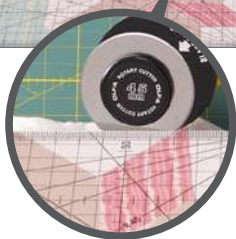

- ① **MQR-30x30** 30cm x 30cm **6x8** **PAT** **GS**
- ② **MQR-15x30** 15cm x 30cm **6x8** **PAT** **GS**
- ③ **MQR-15x60** 15cm x 60cm **6x8** **PAT** **GS**

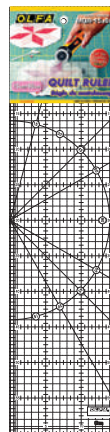

Scale **cm**

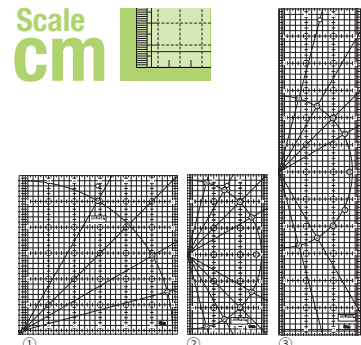

- ④ **QR-16S** 16.5" x 16.5" **6x4**
- ⑤ **QR-12S** 12.5" x 12.5" **6x8**
- ⑥ **QR-9S** 9.5" x 9.5" **6x8**
- ⑦ **QR-6S** 6.5" x 6.5" **6x10**
- ⑧ **QR-4S** 4.5" x 4.5" **6x10**
- ⑨ **QR-2S** 2.5" x 2.5" **12x20**
- ⑩ **QR-6RT** 6.5" RIGHT TRIANGLE **6x10**
- ⑪ **QR-1x12** 1 1/4" x 12.5" **12x20**
- ⑫ **QR-6x12** 6" x 12" **6x8** **PAT**
- ⑬ **QR-6x24** 6" x 24" **6x8** **PAT**



Scale **inch**

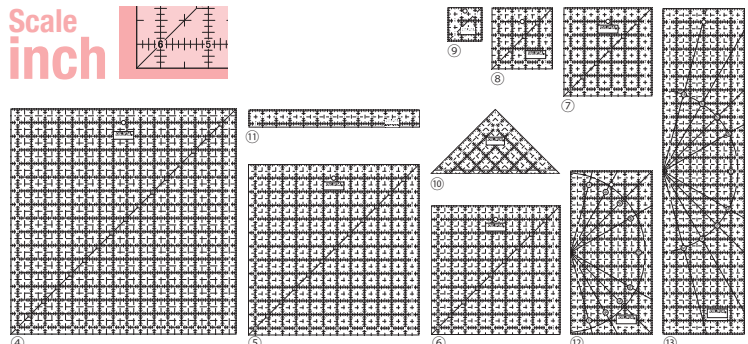

Scissors

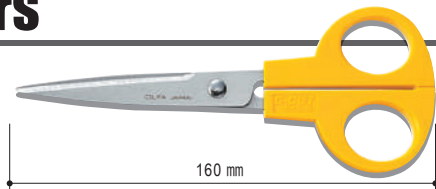

160 mm

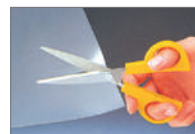

SCS-3



STAINLESS STEEL BLADE



6x20

- High cost-performance model.
- Preis-Leistungs-Modell.
- Modèle d'un excellent rapport qualité-prix.
- Modelo de alto rendimiento.



173 mm

SCS-2



STAINLESS STEEL BLADE



6x20

- Tough serrated scissors, Large
- Grob gezackte Scheren, Groß
- Ciseaux dentés résistants, grand modèle
- Tijeras dentadas resistentes, Grandes



127 mm

SCS-1



STAINLESS STEEL BLADE



6x20

- Tough serrated scissors, Small
- Grob gezackte Scheren, Klein
- Ciseaux dentés résistants, petit modèle
- Tijeras dentadas resistentes, Pequeñas

Other Purpose-Made Hand Tools

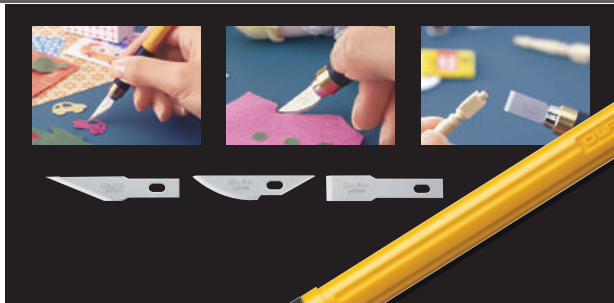

AK-4

KB4-WS/-S/-R/-NS/-F/KB

- Premium art knife with soft grip.
- Erstklassiges Kunstmesser mit weichem Griff.
- Couteau d'art de qualité supérieure avec poignée molle.
- Cortador artístico premium con mango suave.

AK-1

KB

AK-1/5B

KB

- Basic art knife.
- Einfaches Kunstmesser.
- Couteau d'art de base.
- Cortador artístico básico.

AK-3

KB-3

- Good for fine design works.
- Gut für feine Designarbeiten.
- Adéquate pour travaux de conception délicate.
- Excelente para trabajos de diseño preciso.



PRC-2

PRB18/RB18

- Handy perforation cutter.
- Handliches Lochungsmesser.
- Cutter de perforation maniable.
- Cortador de perforación práctico.

PRC-3

PRB28/RB28

- Powerful perforation cutter.
- Kraftvolles Lochungsmesser.
- Cutter de perforation puissant.
- Cortador de perforación potente.

AUTO LOCK



UTC-1

SKB-2/RSKB-2/HOB-2

- Tough cutter with thick trapezoid blade.
- Grobes Messer mit dicker Trapezklinge.
- Cutter résistant avec lame trapézoïdale épaisse.
- Cortador resistente con cuchilla trapezoidal gruesa.

HOK-1

HOB-1

- Powerful hook cutter.
- Kraftvolles Hakenmesser.
- Cutter à crochet puissant.
- Cortador de gancho potente.

45° oblique cutting, for picture mounts.

- Coupe oblique à 45°, pour montage d'image.
- 45° Schrägschneiden, für Bildhalterungen.
- Corte oblicuo de 45°, para foto montajes.



MC-45

MCB-1

MC-45/2B

MCB-1

Advanced model "DX" with guide ruler.

- Modèle perfectionné avec règle de repère.
- Erweitertes Modell mit Führungslineal.
- Modelo avanzado con regla guía.

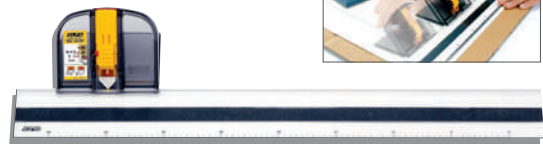

MC-45/DX

MCB-1

Carpet / Lino cutter.

- Cutter pour moquette/lino.
- Teppich- / Linoleummesser.
- Cortador de moqueta / lino.



45-C

Plastic Cutters housing 2 extra blades inside. Score on plastic plate to break off.

- Cutters en plastique avec 2 lames supplémentaires. Notation sur plaque en plastique pour découpe.
- Plastikmesse mit 2 extra Klingen. Zum Abbrechen auf Kunststoffplatte anritzen.
- Cortadores de plástico con 2 cuchillas adicionales. Raya placas de plástico para posteriormente romperlas.



PC-L



PB-800



6x20



PC-S



PB-450



6x20



CK-1



CKB-1



6x40

- Both edges can be used.
- Les deux bords peuvent être utilisés.
- Beide Klingen können verwendet werden.
- Se pueden usar ambos filos.

CK-2



CKB-2



6x40

- All stainless steel model.
- Tous les modèles sont en acier inoxydable.
- Modell komplett aus Edelstahl.
- Todos los modelos son de acero inoxidable.



SK-3



SKB2/HOB2/RSKB2



6x40

- With thick trapezoid blade.
- Avec lame trapézoïdale épaisse.
- Mit dicker Trapezklinge.
- Con cuchilla trapezoidal gruesa.



CTN-1



CTB



24x20

CTN-1/40



CTB



40x12

- Carton cutter with snap-off blade.
- Cutter à carton avec lame sécable.
- Kartonmesser mit Abknick- & Klinge.
- Cortador para cartón con cuchilla desglosable.

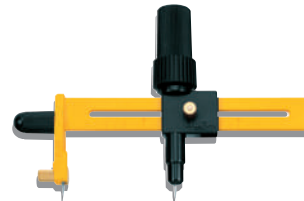
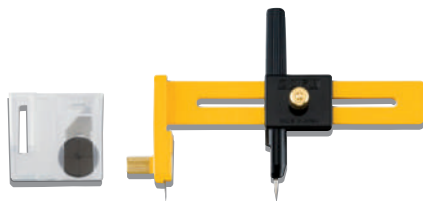

CMP-1



COB-1



6x20

- Cuts circles in dia. 1-15 cm
- Permet de découper des cercles de 1 à 15 cm de diamètre
- Schneidet Kreise im Durchm. 1-15 cm
- Corta círculos en diámetros de 1 a 15 cm



CMP-1/DX



COB-1



6x20

- Ratchet circle cutter in dia. 1.6-22 cm
- Cutter rotatif à rochet de diamètre de 1,6 à 22 cm
- Knarrenkreismesser im Durchm. 1,6 - 22 cm
- Cortador con carrete que corta círculos de diámetro de 1,6 a 22 cm



Incredible, cuts only the top sheet.

- Incroyable, permet de ne couper que la feuille supérieure.
- Unglaublich, schneidet nur das obere Blatt.
- Increíble, corta únicamente la hoja superior.



TS-1



TSB-1



6x20



Pocket-sized, ideal for private imprinting.

- Format de poche, idéal pour l'impression privée.
- Taschenformat, ideal für private Einprägungen.
- A tamaño bolsillo, ideales para la impresión privada.

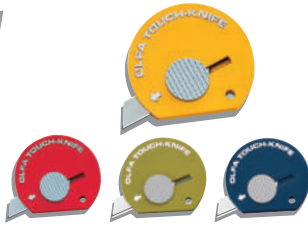

Magnetic Touch Knife.

- Couteau tactile magnétique.
- Magnetisches Kontaktmesser.
- Cortador magnético de bolsillo.



TK-4/60 60x20

TK-4/32 32x30



TK-3M/24 24x30



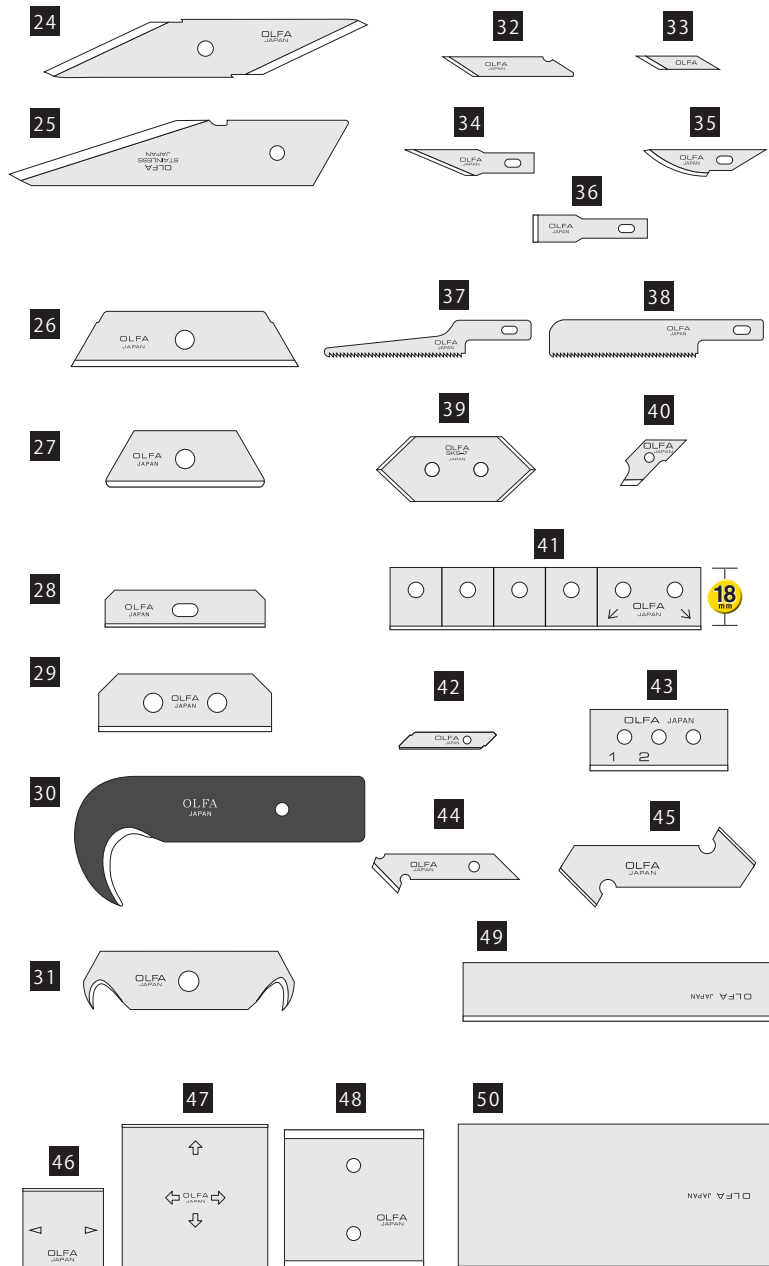
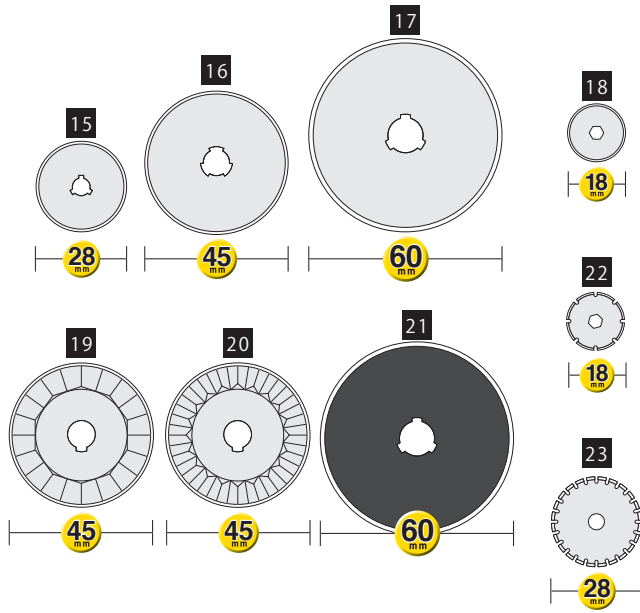
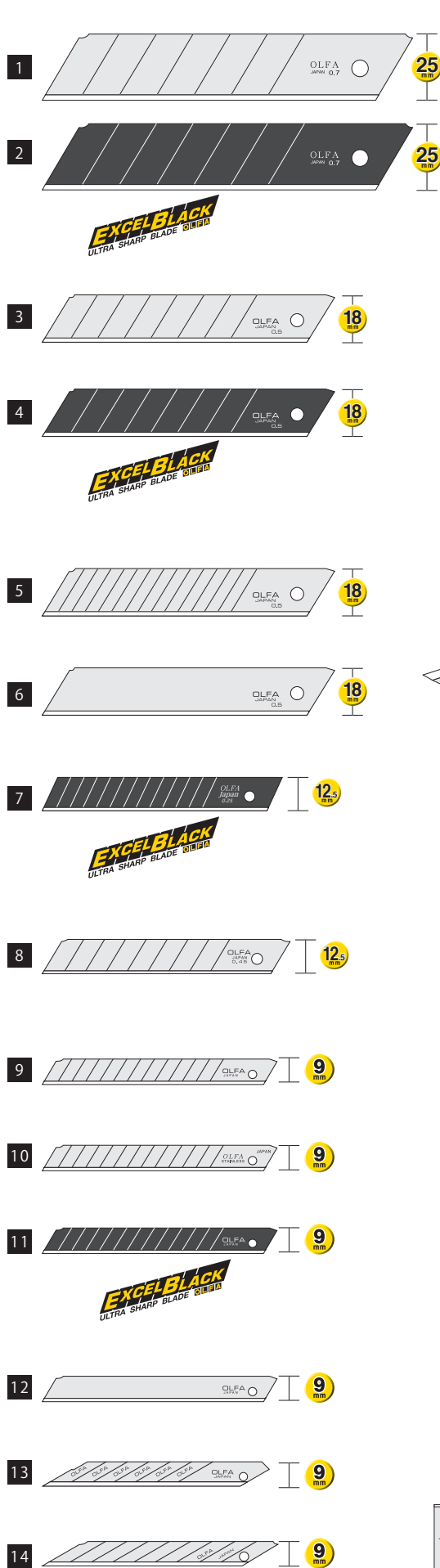



Blades







| | | | | | | |
|--|--|---|---|--|--|---|
|  Model Number |  Packaging |  Contents |  Carton Contents |  Blister Packed |  Plastic Case |  Plastic Bag |
|  Numéro du Modèle |  Emballage |  Contenu |  Contenu de Carton |  Emballage Blister |  Étui Plastique |  Sachet Plastique |
|  Modell Nummer |  Verpackung |  Kartoinhalt |  Kartoinhalt |  Blister Packung |  Kunststoffbox |  Kunststoffbeutel |
|  Numero de Modelo |  Embalaje |  contenido |  Contenido de Embalaje |  Presentado en Blister |  Caja de Plástico |  Bolsa de Plástico |

| | | | |
|-------------|---|----|------|
| 1 HB | | | |
| HB-5B |  | 5 | 6x20 |
| HB-20 |  | 20 | 6x10 |

| | | | |
|-----------------|---|---|------|
| 2 HBB-5B | | | |
| HBB-5B |  | 5 | 6x20 |

| | | | |
|-------------|---|----|------|
| 3 LB | | | |
| LB-6B |  | 6 | 6x40 |
| LB-10 |  | 10 | 6x40 |
| LB-10B |  | 10 | 6x40 |
| LB-50 |  | 50 | 6x10 |
| LB-50B |  | 50 | 6x6 |







| | | | |
|--------------|---|----|------|
| 4 LBB | | | |
| LBB-10 |  | 10 | 6x40 |
| LBB-10B |  | 10 | 6x40 |
| LBB-50 |  | 50 | 6x10 |



| | | | |
|--------------|---|----|------|
| 5 LBD | | | |
| LBD-10 |  | 10 | 6x40 |
| LBD-50 |  | 50 | 6x10 |



| | | | |
|------------------|---|----|------|
| 6 LSOL-10 | | | |
| LSOL-10 |  | 10 | 6x40 |

| | | | |
|--------------|---|----|------|
| 7 FWB | | | |
| FWB-10 |  | 10 | 6x20 |



| | | | |
|----------------|---|----|------|
| 8 MTB-1 | | | |
| MTB-1 |  | 10 | 6x40 |

| | | | |
|-------------|---|----|-------|
| 9 AB | | | |
| AB-6 |  | 6 | 10x60 |
| AB-10 |  | 10 | 6x80 |
| AB-10B |  | 10 | 6x40 |
| ASB-10 |  | 10 | 12x60 |
| AB-50 |  | 50 | 6x20 |
| AB-50B |  | 50 | 6x20 |



| | | | |
|----------------|---|----|------|
| 10 AB-S | | | |
| AB-10S |  | 10 | 6x80 |
| AB-50S |  | 50 | 6x20 |



| | | | |
|---------------|---|----|-------|
| 11 ABB | | | |
| ASBB-10 |  | 10 | 12x60 |
| ABB-10B |  | 10 | 6x40 |
| ABB-50 |  | 50 | 6x20 |

| | | | |
|---------------------|---|----|------|
| 12 AB-SOL-50 | | | |
| AB-SOL-50 |  | 50 | 6x20 |

| | | | |
|---------------|---|----|-------|
| 13 SAB | | | |
| SAB-10 |  | 10 | 10x60 |
| SAB-10B |  | 10 | 6x40 |

| | | | |
|-----------------|---|---|--------|
| 14 DKB-5 | | | |
| DKB-5 |  | 5 | 100x10 |

| | | | |
|----------------|---|----|------|
| 15 RB28 | | | |
| RB28-2 |  | 2 | 6x80 |
| RB28-10 |  | 10 | 6x10 |

| | | | |
|----------------|---|----|------|
| 16 RB45 | | | |
| RB45-1 |  | 1 | 6x80 |
| RB45-10 |  | 10 | 6x10 |

| | | | |
|------------------|---|---|------|
| 17 RB60-1 | | | |
| RB60-1 |  | 1 | 6x40 |

| | | | |
|------------------|---|---|------|
| 18 RB18-2 | | | |
| RB18-2 |  | 2 | 6x80 |

| | | | |
|-------------------|---|---|------|
| 19 WAB45-1 | | | |
| WAB45-1 |  | 1 | 6x40 |

| | | | |
|-------------------|---|---|------|
| 20 PIB45-1 | | | |
| PIB45-1 |  | 1 | 6x40 |

| | | | |
|-----------------|---|---|------|
| 21 CHB-1 | | | |
| CHB-1 |  | 1 | 6x20 |

| | | | |
|-------------------|---|---|------|
| 22 PRB18-2 | | | |
| PRB18-2 |  | 2 | 6x80 |

| | | | |
|-------------------|---|---|------|
| 23 PRB28-2 | | | |
| PRB28-2 |  | 2 | 6x40 |

| | | | |
|-----------------|---|---|------|
| 24 CKB-1 | | | |
| CKB-1 |  | 2 | 6x40 |

| | | | |
|-----------------|---|---|------|
| 25 CKB-2 | | | |
| CKB-2 |  | 2 | 6x40 |

| | | | |
|--------------------|---|---|------|
| 26 SKB-2/5B | | | |
| SKB-2/5B |  | 5 | 6x40 |

| | | | |
|--------------------|---|---|------|
| 27 RSKB-2/5 | | | |
| RSKB-2/5 |  | 5 | 6x40 |

| | | | |
|---------------------|---|----|------|
| 28 SKB-7/10B | | | |
| SKB-7/10B |  | 10 | 6x40 |

| | | | |
|---------------------|---|----|------|
| 29 SKB-8/10B | | | |
| SKB-8/10B |  | 10 | 6x40 |

| | | | |
|-----------------|---|---|------|
| 30 HOB-1 | | | |
| HOB-1 |  | 1 | 6x40 |

| | | | |
|-----------------|---|---|-------|
| 31 HOB-2 | | | |
| HOB-2 |  | 5 | 24x10 |

| | | | |
|--------------|---|----|------|
| 32 KB | | | |
| KB |  | 25 | 6x40 |

| | | | |
|----------------|---|----|------|
| 33 KB-3 | | | |
| KB-3 |  | 30 | 6x40 |

| | | | |
|-------------------|---|---|------|
| 34 KB4-S/5 | | | |
| KB4-S/5 |  | 5 | 6x40 |

| | | | |
|-------------------|--|---|------|
| 35 KB4-R/5 | | | |
| KB4-R/5 |  | 5 | 6x40 |

| | | | |
|-------------------|---|---|------|
| 36 KB4-F/5 | | | |
| KB4-F/5 |  | 5 | 6x40 |

| | | | |
|--------------------|---|---|------|
| 37 KB4-NS/3 | | | |
| KB4-NS/3 |  | 3 | 6x40 |

| | | | |
|--------------------|---|---|------|
| 38 KB4-WS/3 | | | |
| KB4-WS/3 |  | 3 | 6x40 |

| | | | |
|-----------------|---|---|------|
| 39 MCB-1 | | | |
| MCB-1 |  | 5 | 6x40 |

| | | | |
|-----------------|---|-------------|------|
| 40 COB-1 | | | |
| COB-1 |  | 15 (3x5) | 6x40 |

| | | | |
|-----------------|---|----|-------|
| 41 CTB-1 | | | |
| CTB-5 |  | 5 | 24x20 |
| CTB-30 |  | 30 | 12x10 |

| | | | |
|-----------------|---|---|------|
| 42 TSB-1 | | | |
| TSB-1 |  | 5 | 6x40 |

| | | | |
|----------------------|---|----|------|
| 43 SKB-10/10B | | | |
| SKB-10/10B |  | 10 | 6x40 |

| | | | |
|------------------|---|---|------|
| 44 PB-450 | | | |
| PB-450 |  | 5 | 6x40 |

| | | | |
|------------------|---|---|------|
| 45 PB-800 | | | |
| PB-800 |  | 3 | 6x40 |

| | | | |
|-----------------|---|----|------|
| 46 TB-25 | | | |
| TB-25 |  | 10 | 6x40 |

| | | | |
|-----------------|---|---|------|
| 47 TB-45 | | | |
| TB-45 |  | 4 | 6x40 |

| | | | |
|-----------------|---|---|------|
| 48 BTB-1 | | | |
| BTB-1 |  | 3 | 6x40 |

| | | | |
|------------------|---|----|-------|
| 49 BS-10B | | | |
| BS-10B |  | 10 | 10x20 |

| | | | |
|------------------|---|---|------|
| 50 BSF-6B | | | |
| BSF-6B |  | 6 | 6x10 |

Cutting Mats

3mm thickness



- Double-sided use. Green mat.
- Utilisation recto-verso. Matériaux écologiques.
- Doppelseitige Verwendung. Grüne Matte.
- Uso bilateral. Felpa verde.



- Double-sided use. Translucent mat.
- Utilisation recto-verso. Matériaux translucides.
- Doppelseitige Verwendung. Durchsichtige Matte.
- Uso bilateral. Felpa translúcido.

NCM-L 90cmx62cm/35"x24"
NCM-M 62cmx45cm/24"x18"
NCM-S 45cmx30cm/18"x12"

5 pcs.
 10 pcs.
 20 pcs.

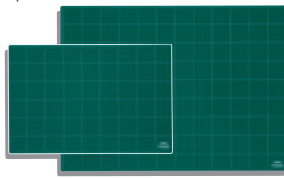

TCM-L 90cmx62cm/35"x24"
TCM-M 62cmx45cm/24"x18"
TCM-S 45cmx30cm/18"x12"

5 pcs.
 10 pcs.
 20 pcs.

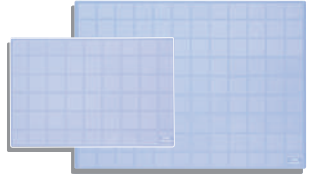

2mm thickness

Most suitable for hobby & craft work. Double-sided use. (Cm/Inch)

- Très approprié pour le bricolage et le travail artisanal. Utilisation recto-verso. (Cm/Pouce)
- Am besten geeignet für Hobby & Handwerksarbeiten. Doppelseitige Verwendung. (Cm/Zoll)
- Excelentes para hobbies y trabajos de artesanía. Uso bilateral. (Cm/Pulgadas)

CM-A1 92cm x 61cm / 36" x 24"
CM-A2 60cm x 43cm / 24" x 17"
CM-A3 43cm x 30cm / 17" x 12"
CM-A4 30cm x 21cm / 12" x 8"

5x2
 5x4
 5x12
 5x20

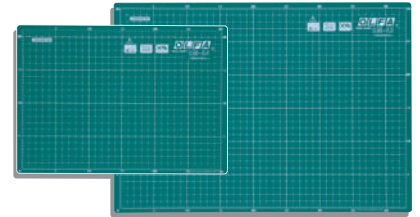
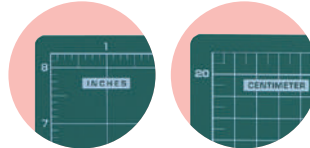
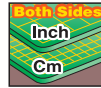

1.5mm thickness

Designed to use with Rotary Cutters. Self-healing triple-layer mats.

- Conçus pour être utilisés avec des cutters rotatifs. Tapis triple couche auto-cicatrisant.
- Entwickelt für die Verwendung mit Rundmessern. Selbstreparierende Dreifach-Schichtmatte.
- Diseñados para su uso con los cortadores rotativos. Felpa de triple capa de auto reparación.

RM-MG 92cm x 61cm / 36" x 24"
RM-SG 60cm x 45cm / 24" x 18"
RM-CG 45cm x 30cm / 18" x 12"

5 pcs.
 5x4
 5x8

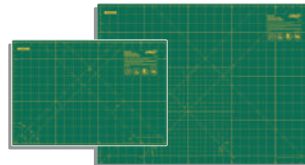

RM-IC-M 92cm x 61cm / 36" x 24"
RM-IC-S 60cm x 45cm / 24" x 18"
RM-IC-C 45cm x 30cm / 18" x 12"

5x2
 5x4
 5x8

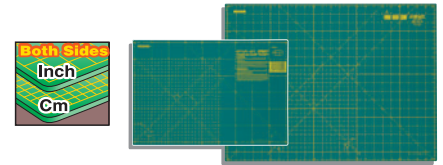

To protect larger working surface.

- Permettent de protéger une surface de travail plus grande.
- Schützt größere Arbeitsoberflächen.
- Protege una mayor superficie de trabajo.

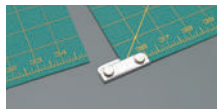

RM-CLIPS/2
 180cm x 60cm / 70" x 24"
 1x3



RM-CLIPS/3
 180cm x 90cm / 70" x 35"
 1x2

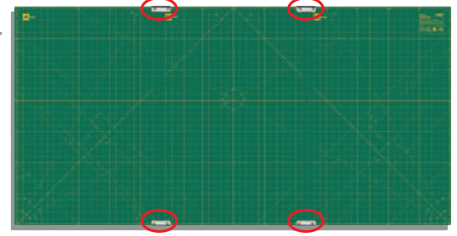

360° rotating for scrapbooking, paper crafts, quilting and modelling.

- Rotation à 360° pour scrapbooking, arts du papier, matelassage, modelage.
- 360° drehend für Sammelalben, Papierhandwerke, Quilts, Modellbau.
- Giro de 360° para el desgarre de libros, manualidades, costura, modelado.

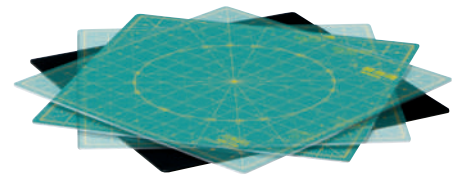

RM-30x30 30cm x 30cm
RM-12S 12" x 12"
RM-17S 17" x 17"

3x8 PAT
 3x8 PAT
 3x3 PAT

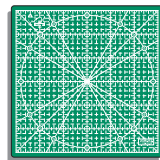

RM-30x30
 Scale: Metric

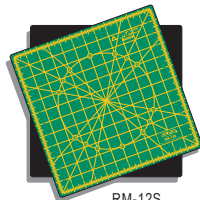

RM-12S
 Scale: Inches

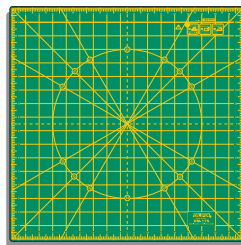

RM-17S
 Scale: Inches



- Keep the mats away from sunlight and heat.
- Ne pas exposer ces plaques à la chaleur ou à la lumière du soleil.
- Halten Sie diese Unterlagen stets vom Sonnenlicht und Hitze fern.
- Manténgalo estas planchas siempre alejados de los rayos solares y del calor.



- Mats must be stored flat.
- Les plaques doivent être entreposées à plat.
- Die Unterlagen müssen flach aufbewahrt werden.
- Los planchos deben guardarse de forma que queden planos.



- Do not leave mats in autos.
- Ne pas laisser les tissus dans les autos.
- Die Matten nicht im Auto lassen.
- No deje las alfombrillas dentro de coches.



- Not suitable for use with steam irons.
- Ne pas utiliser avec un fer à repasser à vapeur.
- Sie eignen sich nicht für die Verwendung mit Dampfbügeleisen.
- No son apropiadas para uso con planchas de vapor.

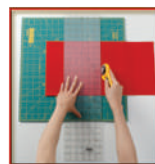

OLFA
 THE ORIGINATOR SINCE 1956

URL <http://www.olfa.com>

MANUFACTURED BY OLFA CORPORATION, OSAKA 537-0021, JAPAN
 Entire contents copyright OLFA CORPORATION All rights reserved.

PRINTED IN JAPAN 2011 JULY-DS